

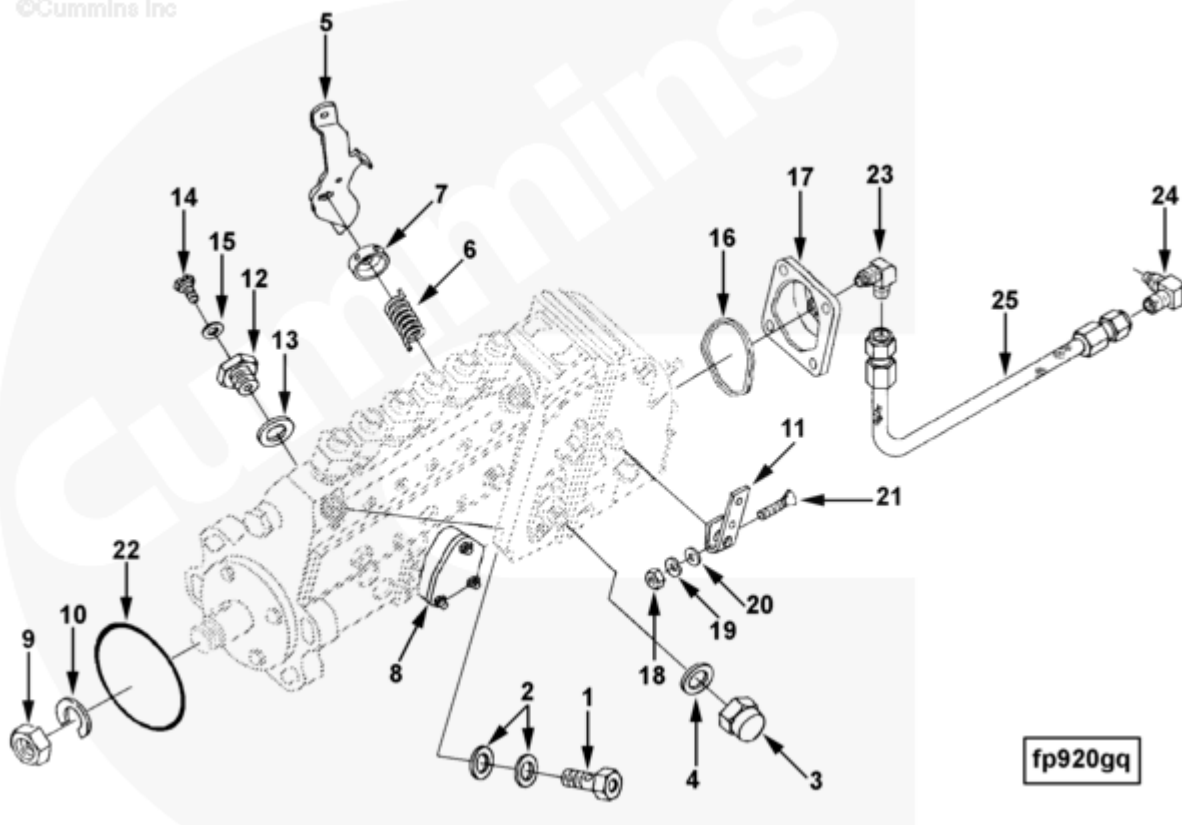

Parts Catalog - Option Detail

Electronic Parts Catalog - Option Detail				
Option	Group	Graphic	Film Card	Date
FP97456	05.21	fp920gq	Z	05-SEP-96
Engines	6C8.3, C GAS PLUS CM556, G8.3, G8.3 CM558, GTA8.3 CM558, ISC CM2150, ISC CM554, ISC CM850, ISC8.3 CM2250, ISC8.3 G CM2180 C101, ISL CM2150, ISL CM554, ISL CM850, ISL G CM2180, ISL8.9 CM2150 L110, ISL8.9 CM2880 L112, ISL9 CM2150 SN, ISL9 CM2250, ISL9 CM2350 L101, ISL9 CM2350 L111, ISLE4 CM850, L GAS PLUS CM556, L8.9, L8.9 L121, L8.9G CMOH2.0 L125B, L9 CM2350 L116B, L9 CM2350 L119B, L9 CM2350 L120C, L9 CM2350 L123B, L9.3 L105, L9.5 L117, L9N CM2380 L124B, QSC8.3 CM2250, QSC8.3 CM2880 C102, QSC8.3 CM554, QSC8.3 CM850(CM2850), QSL9 CM2250, QSL9 CM2250 L115, QSL9 CM2350 L102, QSL9 CM2350 L107, QSL9 CM2350 L118, QSL9 CM2350 L122, QSL9 CM554, QSL9 CM850(CM2850), QSL9 G CM558, QSL9 M CM2250 L106, QSL9.3 CM2880 L113			



[SMALL](#) | [MEDIUM](#) | [LARGE](#)

Cart	Ref No	Part Number	Part Description	Required	Remarks
View My Cart					
		FP97456	Fuel Pump		Fuel Pump
		FP97456	Fuel Pump		Fuel Pump
					Engine Family: C Series
					Engine Family: C Series

					Engine Cylinders: 6
					Engine Cylinders: 6
					Advertised HP: 207 @ 1800
					Advertised HP: 207 @ 1800
					Fuel Pump Type: Inline
					Fuel Pump Type: Inline
					Pump Manufacturer/Model:
					Pump Manufacturer/Model:
					Bosch A
					Bosch A
					High Idle: 1837
					High Idle: 1837
					Governor Type: RSV
					Governor Type: RSV
					Solenoid Activation: ATR
					Solenoid Activation: ATR
					High Pressure Tube ID (mm):
					High Pressure Tube ID (mm):
					2.0
					2.0
					Shutdown Device: Manual
					Shutdown Device: Manual
					Shutoff Lever Design: Direct
					Shutoff Lever Design: Direct
					link
					link
					Compatible Fuel Rating - FR:
					Compatible Fuel Rating - FR:
					9196
					9196

					CPL: 0985
					CPL: 0985
					Certified by: Non certified
					Certified by: Non certified
					Governor Break RPM: 1810
					Governor Break RPM: 1810
					Governor Regulation (%): 1.5
					Governor Regulation (%): 1.5
					Continuous Duty Rating with
					Continuous Duty Rating with
					4% governing.
					4% governing.
					Mask high idle screw prior to
					Mask high idle screw prior to
					painting pump.
					painting pump.
<input type="checkbox"/>	1	3921160	Fuel Injection Pump	1	
<input type="checkbox"/>	1	3912886	Check Valve	1	
<input type="checkbox"/>	2	3912887	Sealing Washer	2	
<input type="checkbox"/>	3	3912888	Timing Plug	1	
<input type="checkbox"/>	4	3912889	Sealing Washer	1	
<input type="checkbox"/>	5	3910979	Shut-Off Valve Lever	1	
<input type="checkbox"/>	6	3912890	Torsion Spring	1	
<input type="checkbox"/>	7	3912891	Return Spring Housing	1	
<input type="checkbox"/>	8	3912892	Feed Pump Gasket	1	
<input type="checkbox"/>	9	3912894	Gear Retaining Nut	1	
<input type="checkbox"/>	10	3912895	Lock Washer	1	
<input type="checkbox"/>	11	3913327	Control Lever	1	
<input type="checkbox"/>	12	3913320	Vent Screw	1	

<input type="checkbox"/>	13	3913321	Sealing Washer	1	
<input type="checkbox"/>	14	3913322	Vent Screw	1	
<input type="checkbox"/>	15	3913323	Sealing Washer	1	
<input type="checkbox"/>	16	3919286	Rectangular Ring Seal	1	
<input type="checkbox"/>	17	3915169	Fuel Pump Cover	1	
<input type="checkbox"/>	18	3920930	Hexagon Nut	1	
<input type="checkbox"/>	19	3907478	Lock Washer	1	
<input type="checkbox"/>	20	3920931	Flat Washer	1	
<input type="checkbox"/>	21	3920929	Throttle Shaft Bolt	1	
<input type="checkbox"/>	22	3910503	O-Ring Seal	1	
<input type="checkbox"/>	23	68139	Male Adapter Elbow	1	1/8 NPTF X 7/16 - 20 (90).
<input type="checkbox"/>	24	3915172	Male Adapter Elbow	1	
<input type="checkbox"/>	25	3906747	Flexible Hose	1	Oil Supply Line